

ADAS-EU: Final Meeting and Special Workshop

Welcome

*Lorne Horton
Head of EFDA JET Department*



- ADAS has had a long and (very) successful association with JET
- The strength of the project, in my opinion, is its firm basis on experimental measurement and interpretation
- With this philosophy, it has been possible to focus scarce resources on important fusion problems and to bring to bear expertise in the atomic physics community that would otherwise not have been available

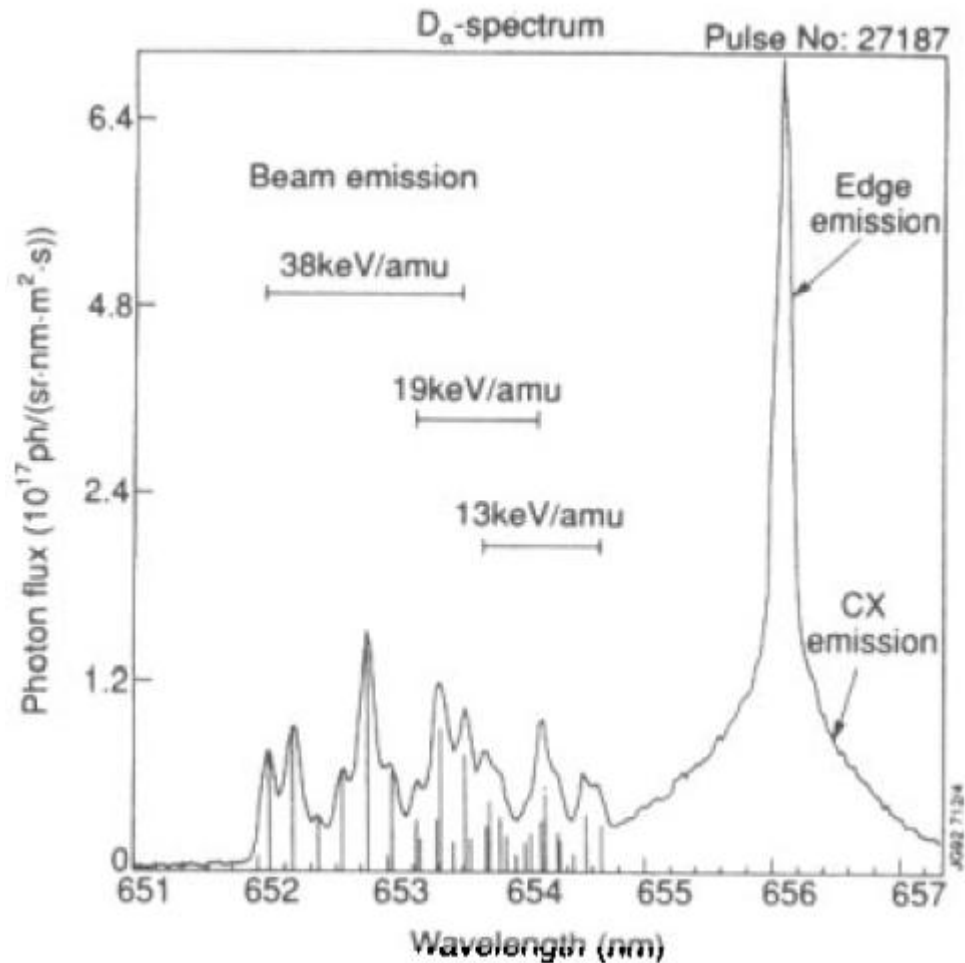

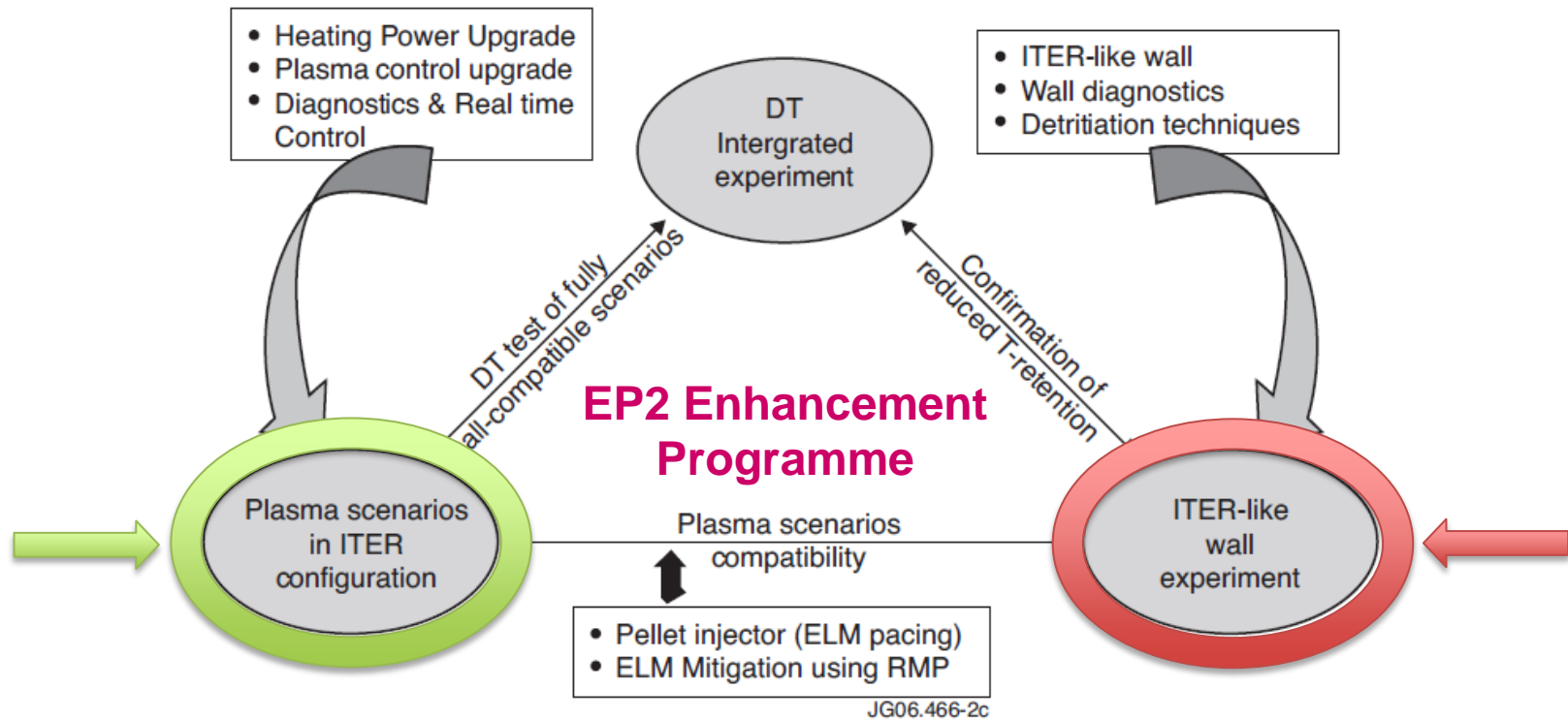

- **Phase 1: 2011-2012** (Deuterium Operation)
“Full Characterisation of the ITER-like Wall”
- **Phase 2: 2013-2015** (Deuterium* Operation)
“Expansion of ITER Regimes of Operation”
- **Phase 3: 2017**
“Deuterium-Tritium Campaigns”

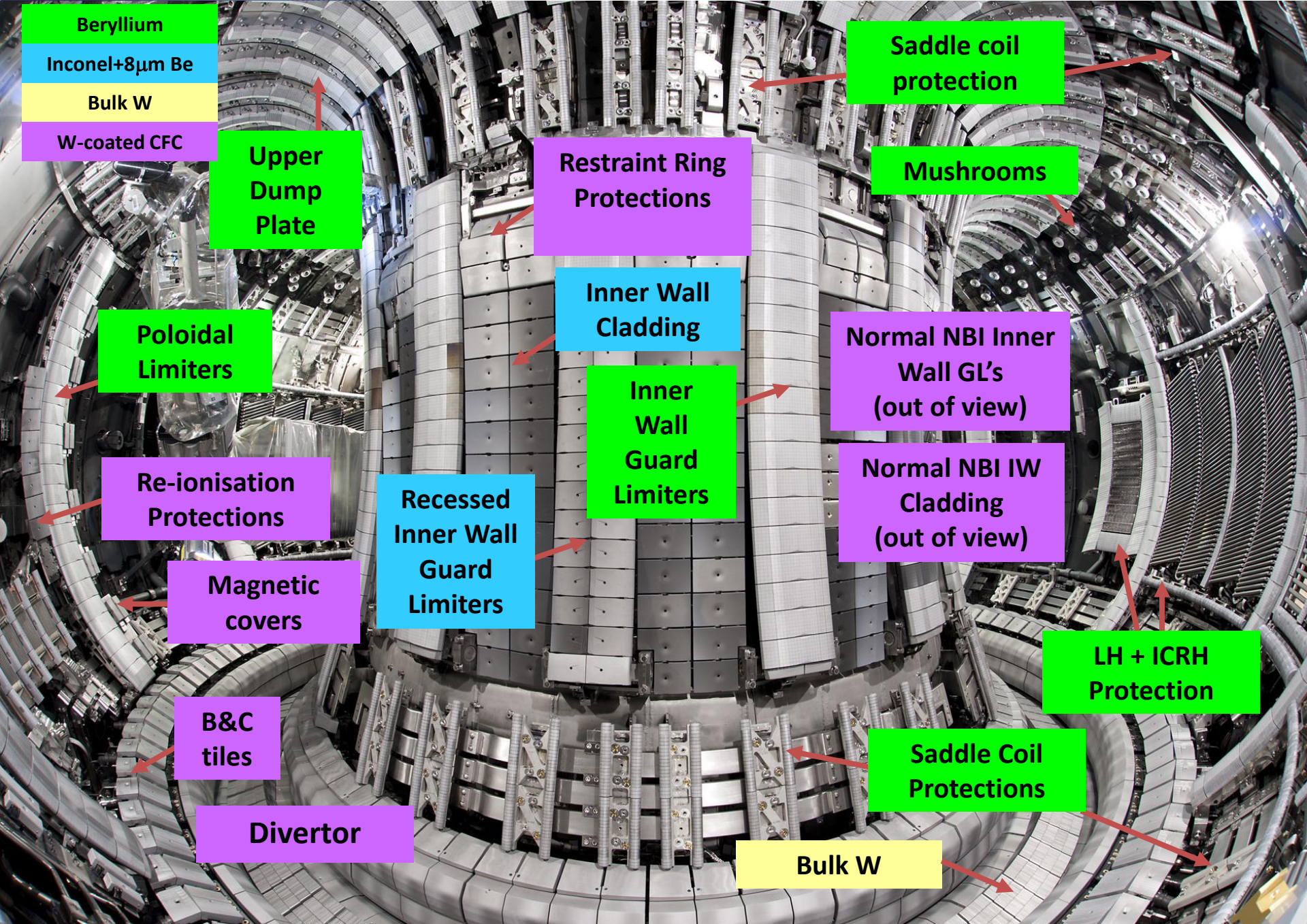

ILW = 2880 installable items, 15828 tiles (~2 tonnes Be, ~2 tonnes W)

Be first wall material qualification: -
 erosion and Be PFC life time
 - power load capability

- Be erosion modelling and atomic data (steady-state) (also molecular data (BeD / BeT))?
- Be erosion by transients (kinetic effects? Do we need to go back to cross sections?)
- Be re-erosion and transport to remote areas (metastable states?)

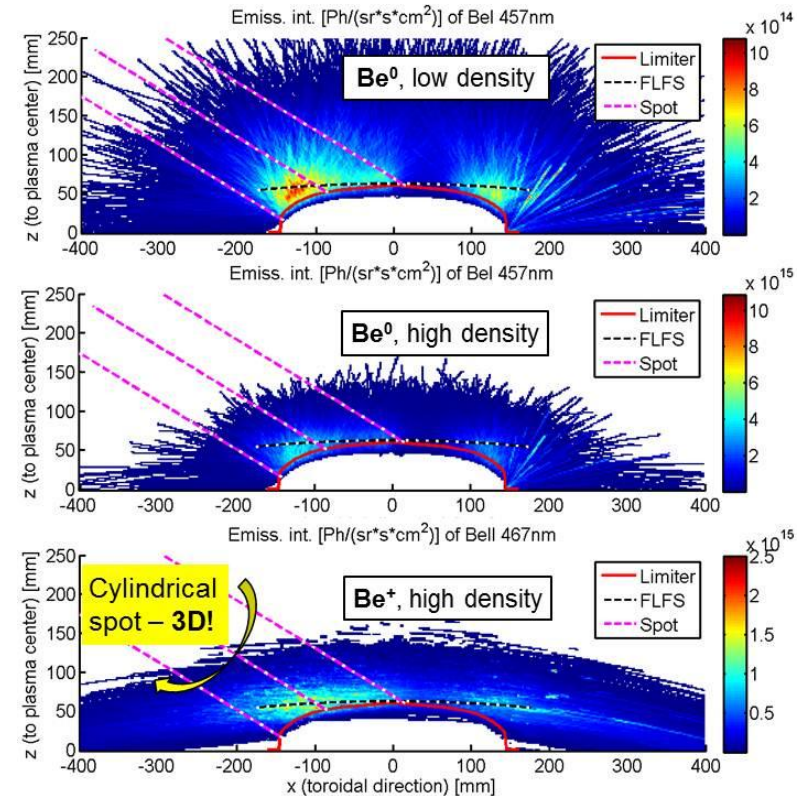

Be first wall material qualification: -
 erosion and Be PFC life time
 - power load capability

- Be erosion modelling and atomic data (steady-state) (also molecular data (BeD / BeT))?
- Be erosion by transients (kinetic effects? Do we need to go back to cross sections?)
- Be re-erosion and transport to remote areas (metastable states?)

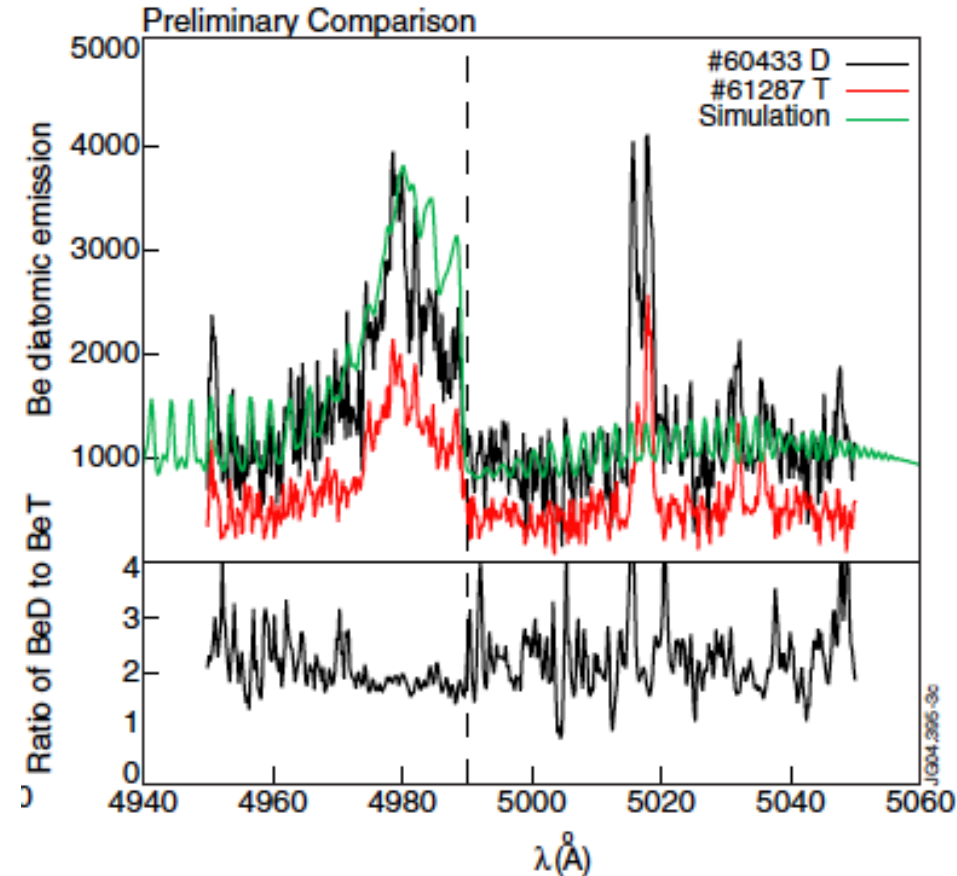

Duxbury et al.

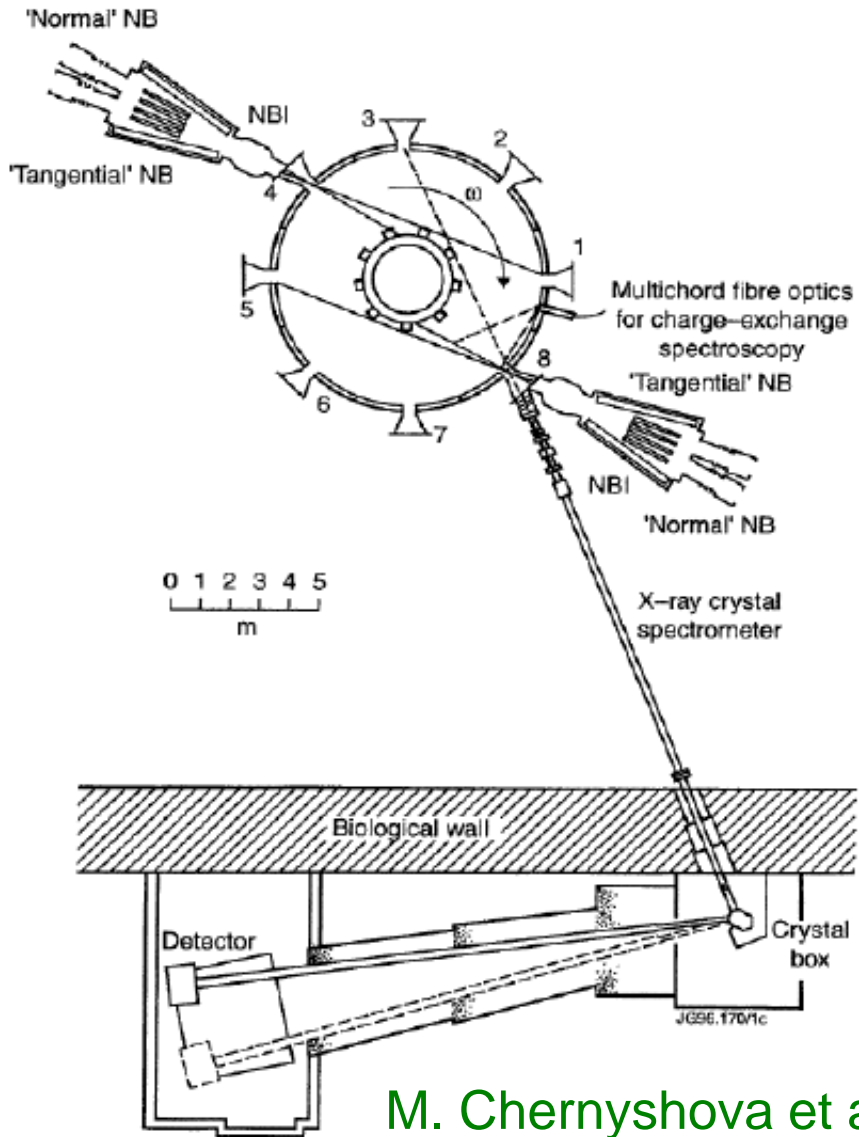

M. Chernyshova et al.

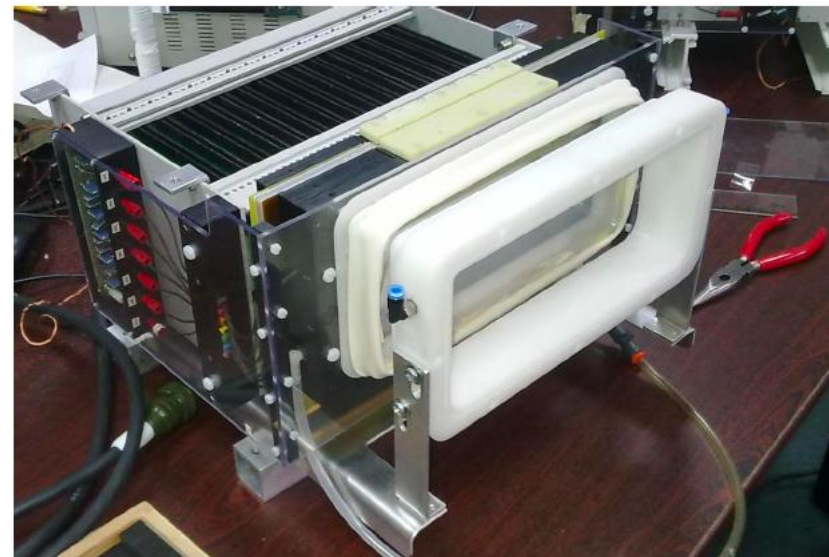
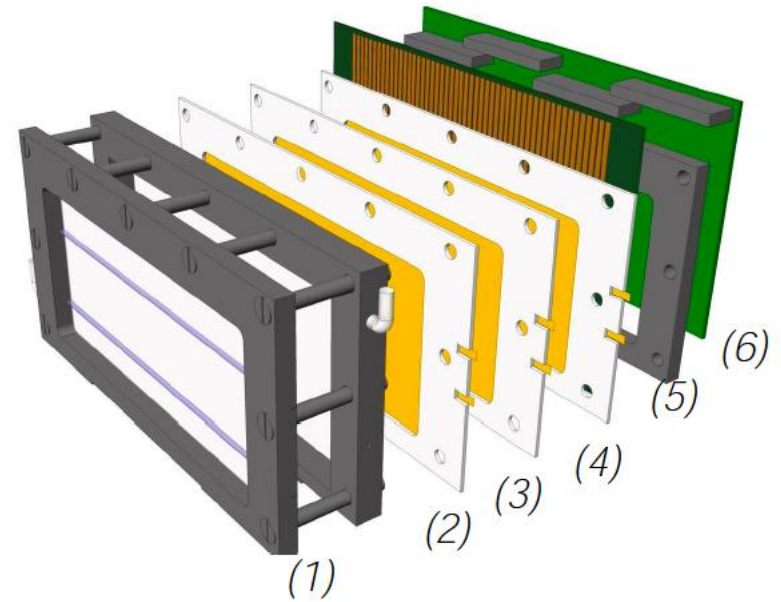

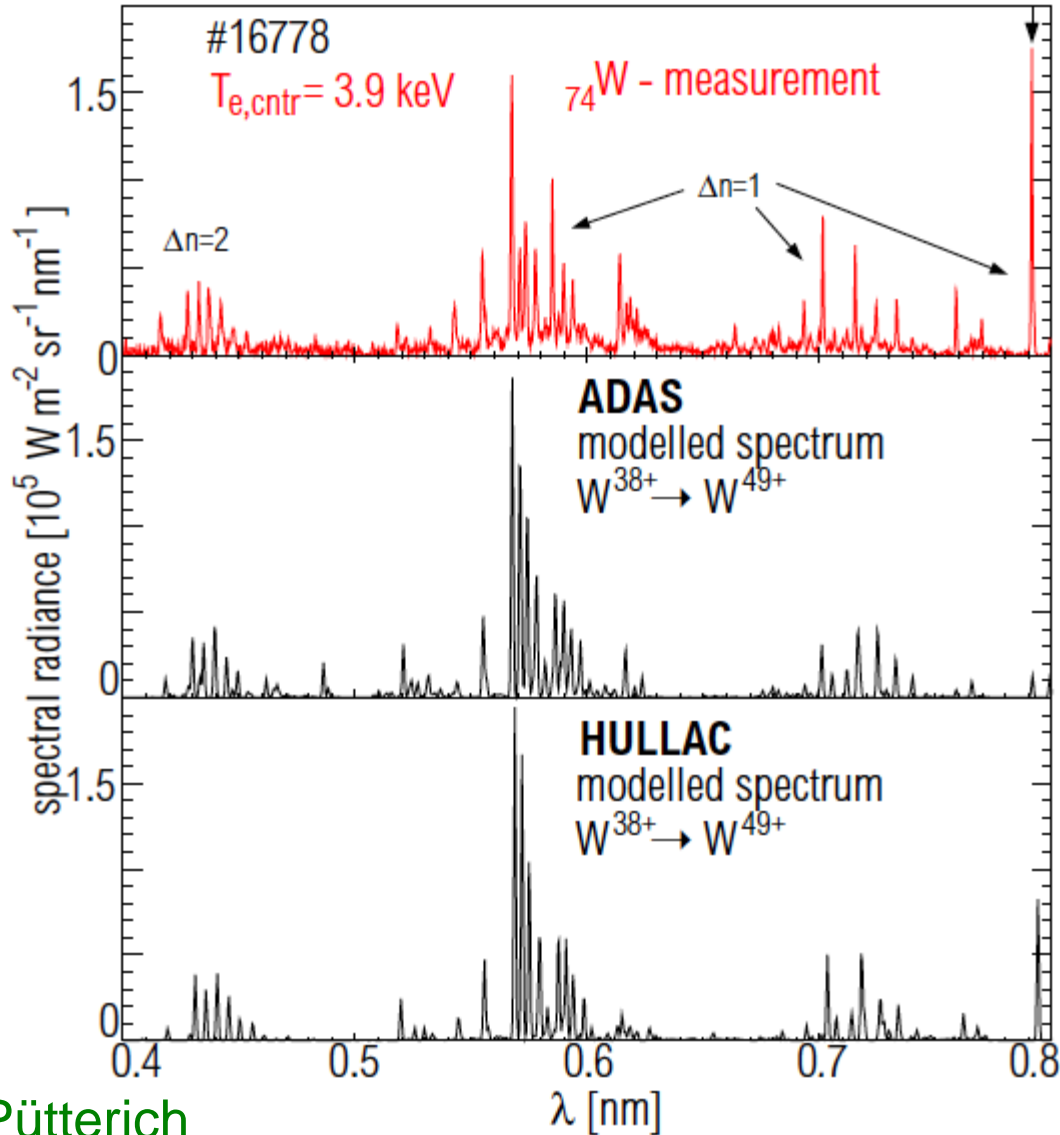

T. Pütterich

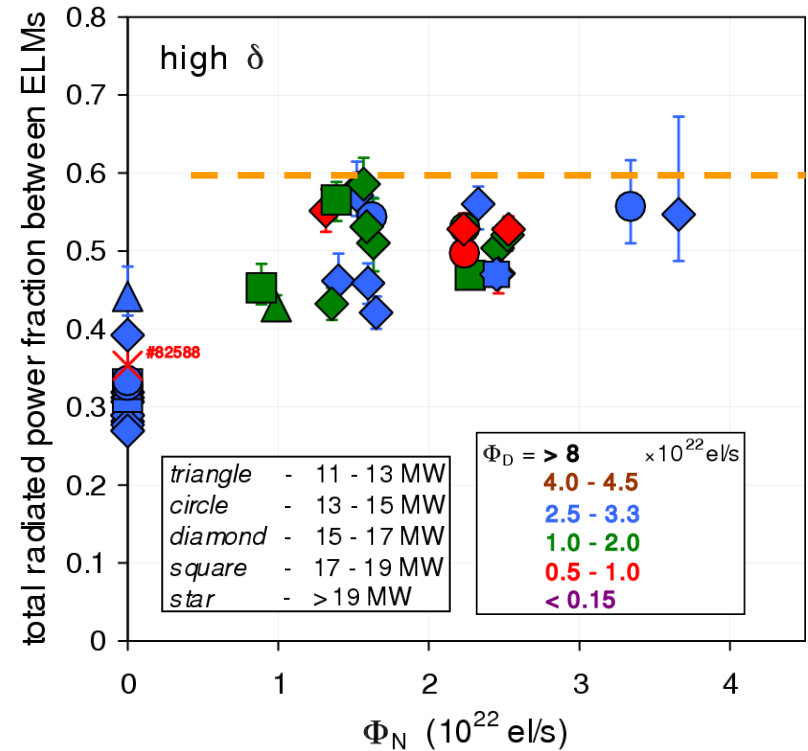
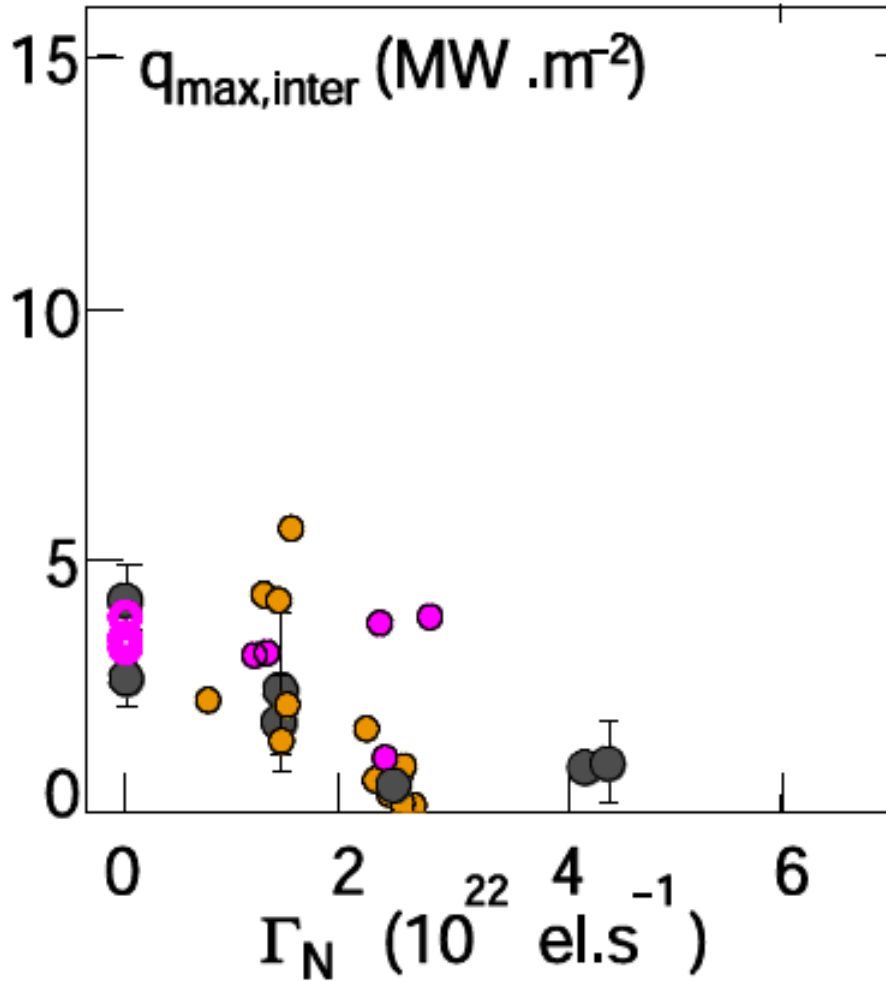

- **JET ILW:** D-fuelling+ N-seeding scans: $f_{\text{RAD}} \leq 0.6$
- **ITER:** $f_{\text{RAD}} > 80\%$
- **DEMO:** $f_{\text{RAD}} \sim 97\%$ is needed

C. Giroud et al.

2.5MA/2.6-2.7T $\delta \sim 0.4$

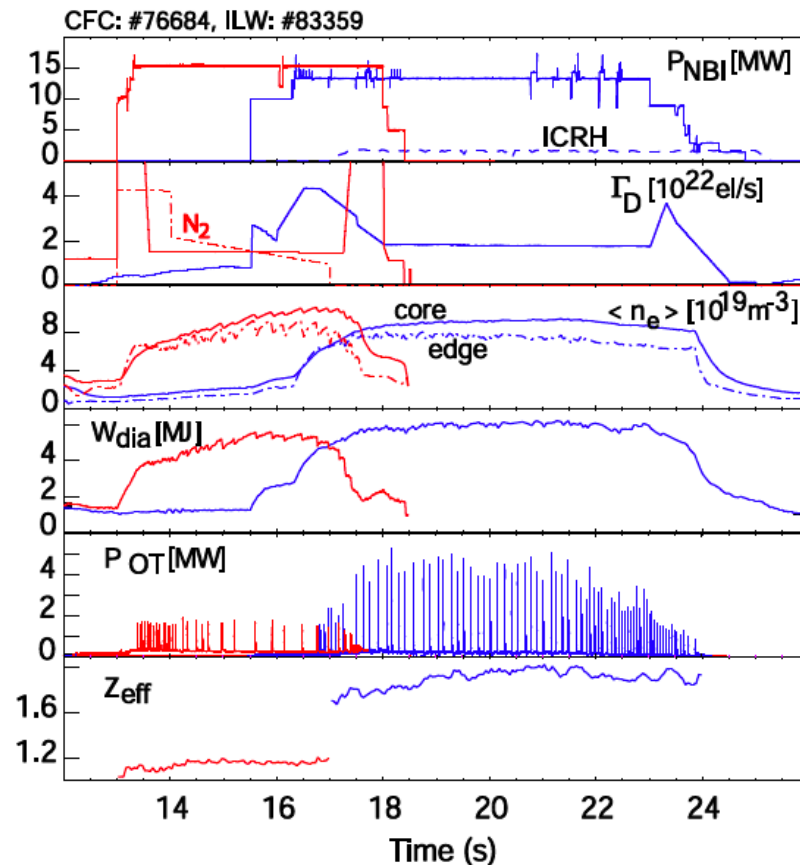
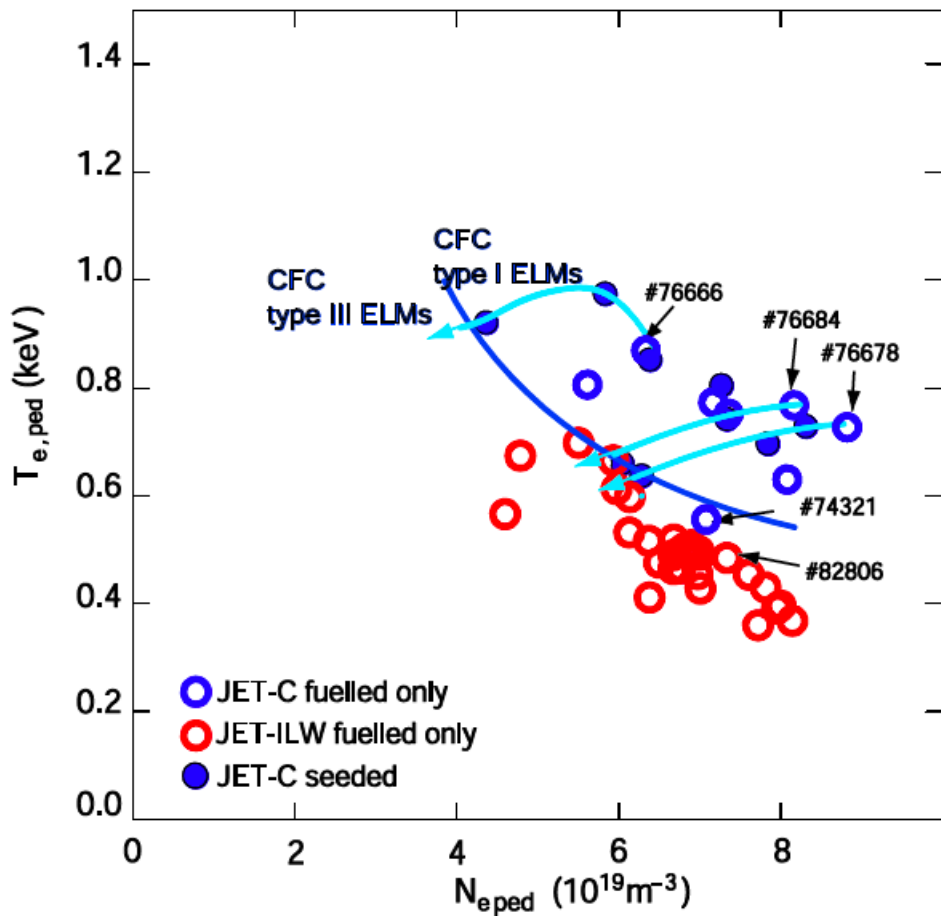

C. Giroud et al.

- The technology in use in ADAS has changed over the years but the rigour applied has remained constant
- ADAS has profited from a series of very bright, very motivated students (it is a young man's game, if only to be able to read Hugh's miniature hand writing)
- It is a credit to Hugh that he been more than able to keep up with these students and I am personally very grateful for his contributions to ADAS and to JET

